

FIG. 1

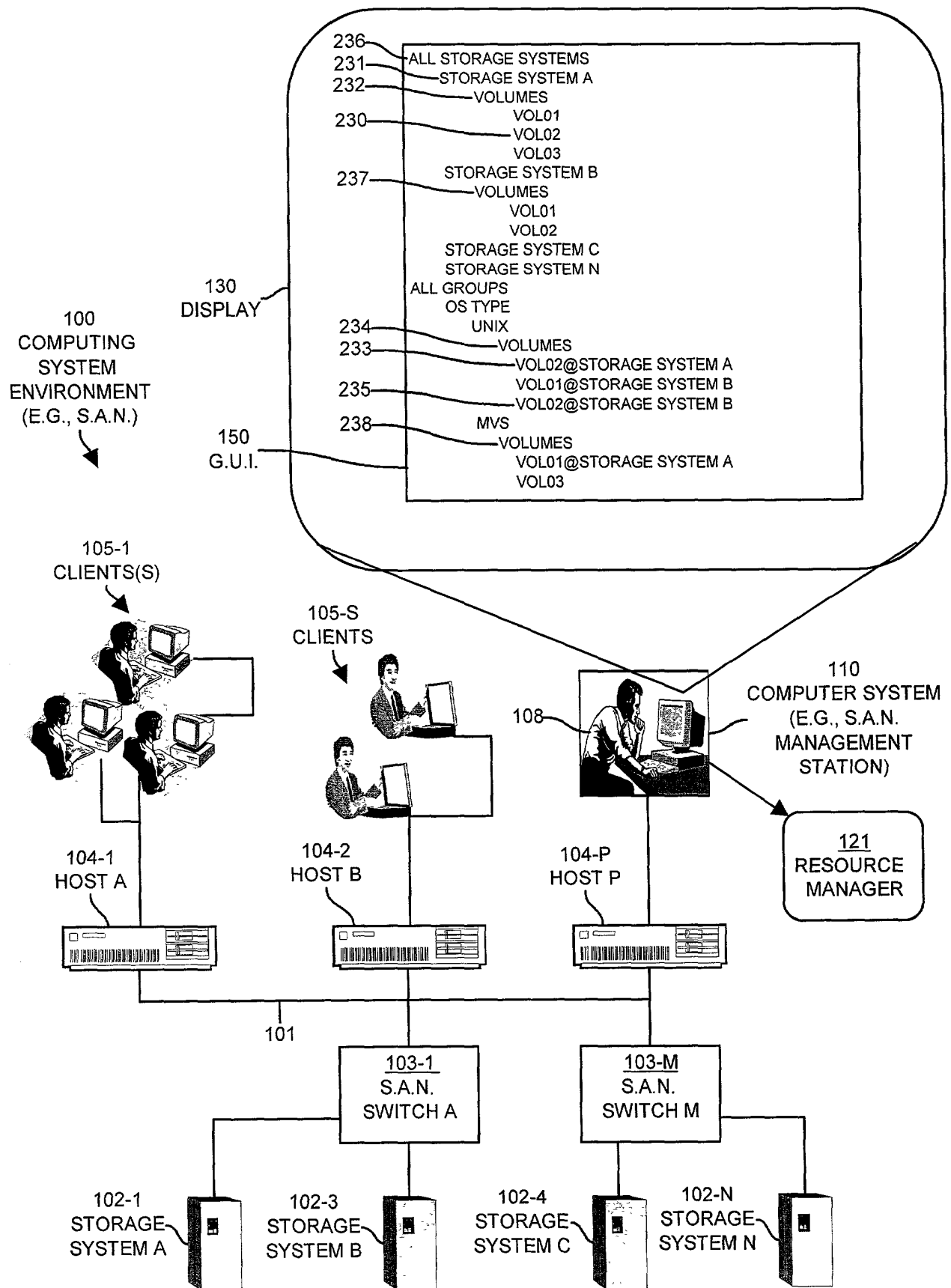

FIG. 1

FIG. 2

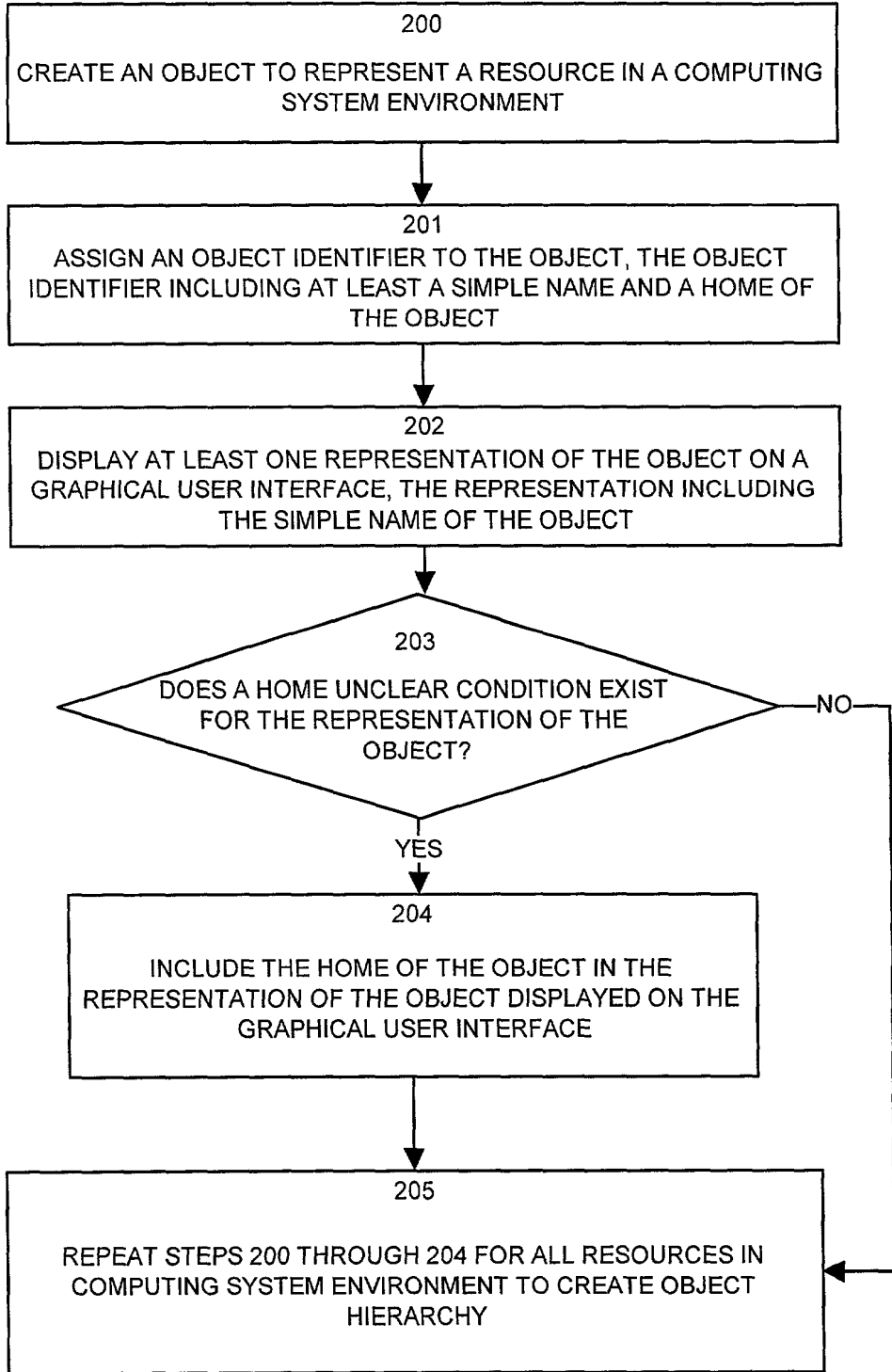

FIG. 2

TOP SECRET 5249660

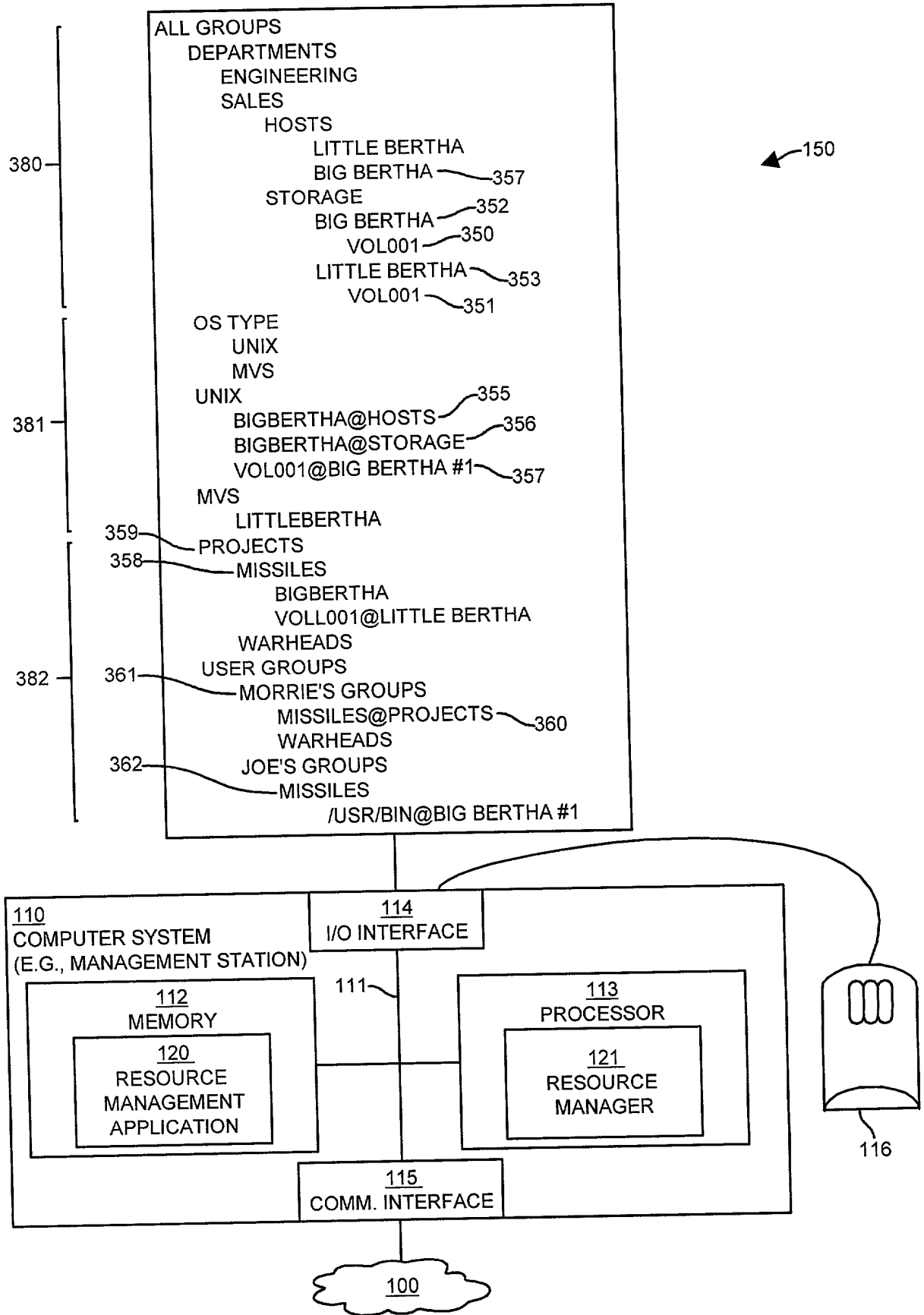

FIG. 3